

IN-SIGHT 7000 SERIES VISION SYSTEM

The In-Sight® 7000 series vision system represents a breakthrough in flexibility, performance and ease of integration. This powerful vision system performs fast, accurate inspections while its compact footprint easily fits into space-constrained production lines. The unique, modular design is highly field-customizable to your application requirements.

Enhanced performance keeps pace with increasing line speeds

With ever-increasing production line speeds, customers no longer have to choose between high-speed and industrial performance—the In-Sight 7000 offers both! With blazing fast acquisition and industry leading vision tools, including PatMax RedLine®, SurfaceFX™ and OCRMax®, the In-Sight 7000 vision system quickly locates the part and accurately performs the necessary inspection.

Flexible design is field customizable to your application

When it comes to factory automation, one size rarely fits all. That's why the In-Sight 7000 is designed with Flexible Image Technology™ (FIT™) that optimizes image formation and minimizes the need for expensive external lighting. Field-changeable and user-configurable lighting and optics modules provide users with ultimate flexibility to customize the system for their application.

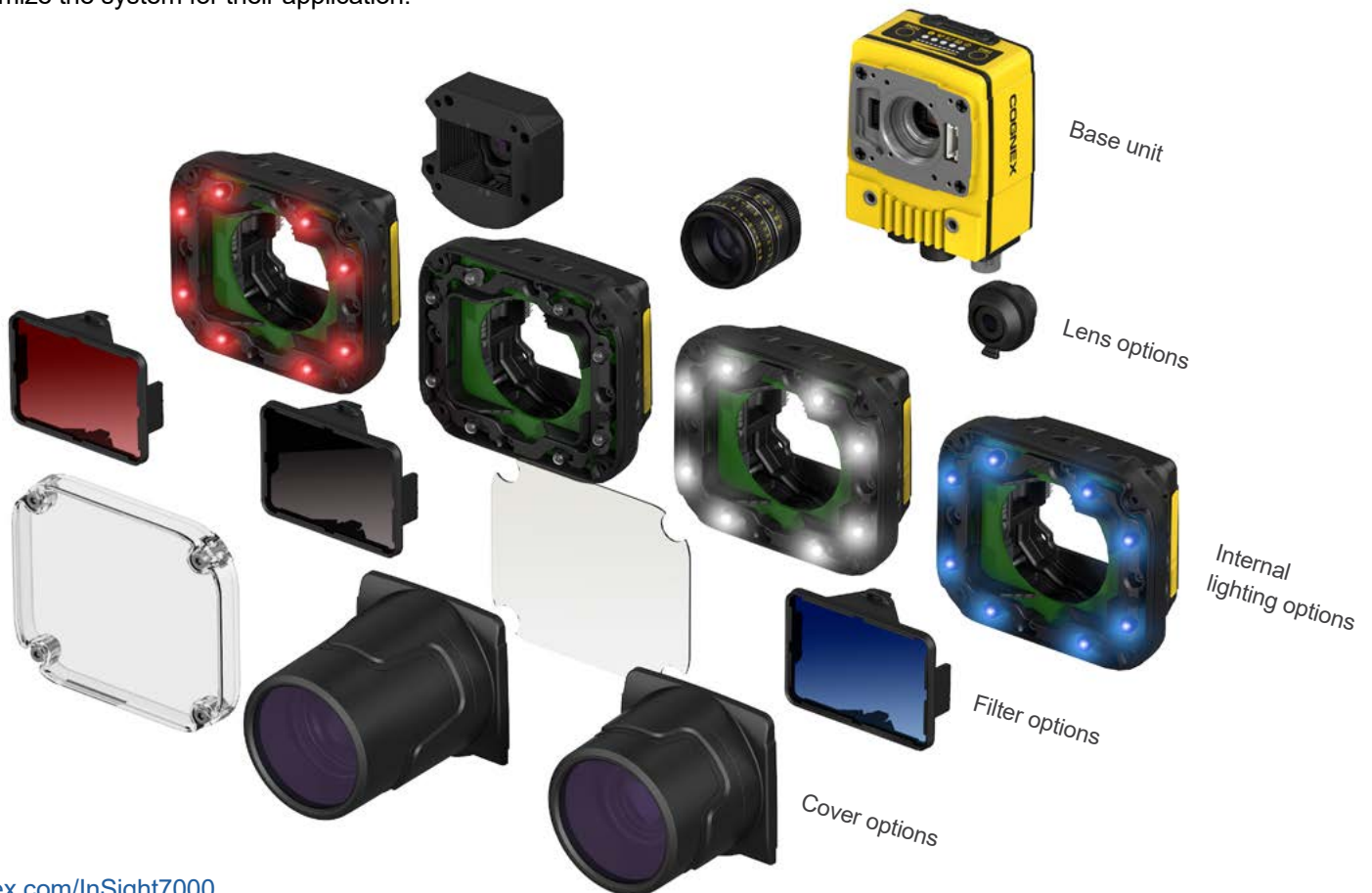

Full-featured system to tackle a wide range of vision applications

The In-Sight 7000 vision system is engineered with the full suite of powerful Cognex vision algorithms and convenient features to help you solve your applications easily and reliably.

Suite of enhanced vision tools including PatMax RedLine, SurfaceFX and OCRMax for rapid part location and inspection.

Onboard SD card for additional data storage and easy transfer of job files between systems.

Flexible Image Technology (FIT) optimizes image formation and minimizes the need for expensive external lighting.

Wrap-around LED indicator light provides clear visual pass/fail inspection results that can be seen from a distance regardless of product orientation.

Field changeable C-mount and S-mount lenses and an autofocus option for best image resolution based on working distance.

IP67-rated housing provides protection in harsh factory environments.



Additional internal lighting options

In addition to other small form factor lights, the In-Sight 7000 is compatible with ImageMax™ technology used with DataMan® 360 series barcode readers. The ImageMax technology module offers diffuse illumination ideal for inspecting parts at varying working distances.



Integrates easily into your system infrastructure

Like all In-Sight vision systems, the In-Sight 7000 uses In-Sight Explorer EasyBuilder® to set up and monitor machine vision inspections. The intuitive interface guides operators through a step-by-step setup process allowing both novice and experienced users to configure vision applications quickly and easily.

The majority of applications can be solved using the point-and-click EasyBuilder interface, however should your application requirements change, the In-Sight spreadsheet provides you with ultimate control through direct access to the vision tools and communication options. Access to the spreadsheet not only provides programming flexibility to make essential adjustments, it also offers assurance that you will be able to solve any of your vision applications.

cognex.com/easybuilder

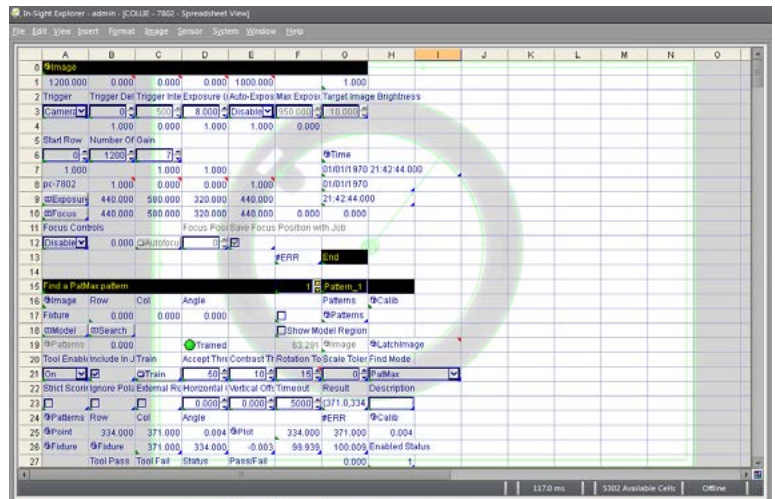

In-Sight spreadsheet provides ultimate control and direct access to vision tools.

The EasyBuilder user interface provides intuitive steps for even the most difficult applications. With no programming or spreadsheets needed, applications are deployed at breakthrough speed.

Four simple steps guide you through the setup process

- 1
- 2
- 3
- 4

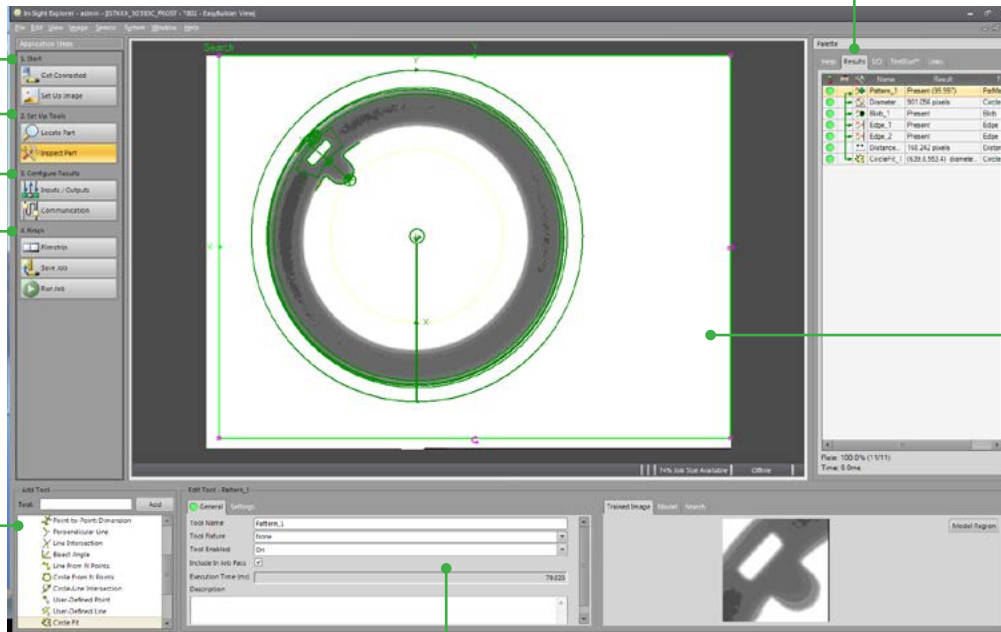

Results table— Consolidates tool results for easy viewing and helps users understand tool dependencies and performance timing

Image centric— Point-and-click approach lets users drop in tools quickly by simply clicking on the features of interest

Tools palette—Comprehensive set of vision tools for locating, measuring, counting and identifying features, plus math, logic, geometry and graphic display tools

Settings pane—Configures all vision tool parameters and settings

SPECIFICATIONS

	In-Sight 7600/7800	In-Sight 7801	In-Sight 7802
Job/Program Memory	7.2 GB on board + 8 GB on SD card (included)		
Image Processing Memory	512 MB		
Additional Storage	8 GB SD card, network drive via FTP over gigabit network		
Operating Temperature	0 °C to 40 °C (32 °C to 104 °F)		
Resolution	640 x 480/800 x 600	1280 x 1024	1600 x 1200
Frames Per Second (FPS)	217/165	76	53
Lens Type	C-mount/S-mount/Autofocus		
Light Options	Internal vision torch light, other add-on lighting options; External light powered by 7000; External light independent power		
Internal Light Color	Red, white, blue, IR		
Indicator LEDs	System status; 360-degree viewing LED indicator ring		
Built in I/O	1 optically isolated trigger input; 1 dedicated input; 2 dedicated outputs; 2 bi-directional lines; RS-232; Additional I/O available via external I/O modules: CIO-MICRO or CIO-1400		
Power	24 VDC ±10%, 1.5 A maximum		
Industrial M12 Connectors	3: Power/I/O; Ethernet; External light power/control		
Weight	240 g		
Protection	IP67 with internal light option or C-mount lens cover		
Network Communications	10/100/1000 BaseT with auto MDIX. IEEE 802.3 TCP/IP Protocol.		
IEEE 1588 Support	Timestamp resolution: 8 ns Synchronization accuracy through transparent clock: 5 μs		

In-Sight 7000 with Internal Lighting

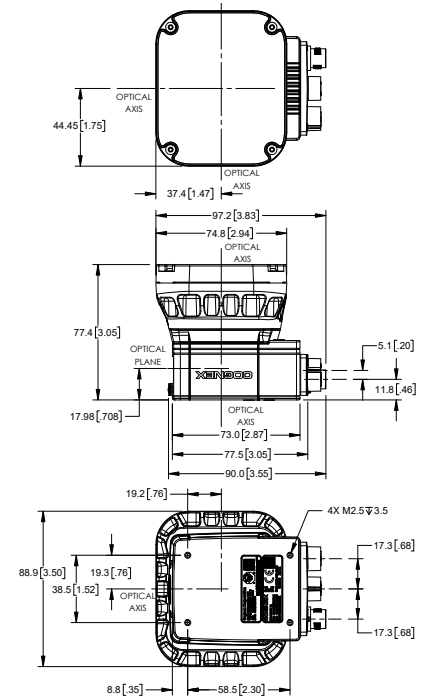

In-Sight 7000 Base Unit

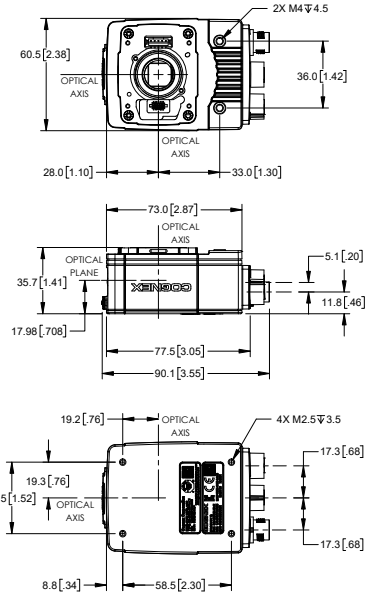

In-Sight 7000 with C-mount Cover

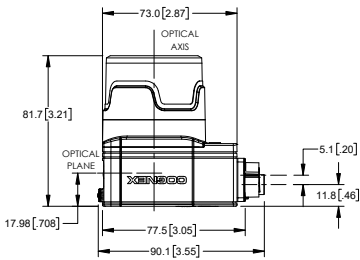

In-Sight 7000 with Extended C-mount Cover

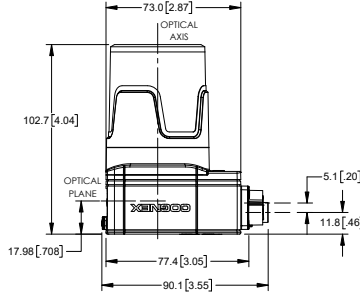

Companies around the world rely on Cognex vision and barcode reading solutions to optimize quality, drive down costs and control traceability.

Corporate Headquarters One Vision Drive Natick, MA 01760 USA

Regional Sales Offices

Americas

North America +1 844-999-2469
Brazil +55 (11) 2626 7301
Mexico +01 800 733 4116

Europe

Austria +49 721 958 8052
Belgium +32 289 370 75
France +33 1 7654 9318
Germany +49 721 958 8052

Hungary +36 30 605 5480
Ireland +44 121 29 65 163
Italy +39 02 3057 8196
Netherlands +31 207 941 398
Poland +48 717 121 086
Spain +34 93 299 28 14
Sweden +46 21 14 55 88
Switzerland +41 445 788 877
Turkey +90 216 900 1696
United Kingdom +44 121 29 65 163

Asia

China +86 21 6208 1133
India +9120 4014 7840
Japan +81 3 5977 5400
Korea +82 2 539 9980
Singapore +65 632 55 700
Taiwan +886 3 578 0060

© Copyright 2017, Cognex Corporation.

All information in this document is subject to change without notice. All Rights Reserved. Cognex, In-Sight, OCRMax, PatMax RedLine, DataMan and Explorer EasyBuilder are registered trademarks of Cognex Corporation. SurfaceFX, Flexible Image Technology, FIT and ImageMax are trademarks of Cognex Corporation. Lit. No. DS-IS7000G2-2017-03

www.cognex.com